

DETERMINING SPRING RATE

STEP 1: DETERMINE TRAVEL

For the spring to be rated, please refer to the specifications listed for your spring part number in this catalog and record the travel measurement. This number represents the total available travel from free height to coil bind.

Our example spring travel measurements for standard:
6.25" metric: 146mm

FREE LENGTH COIL BIND TOTAL TRAVEL

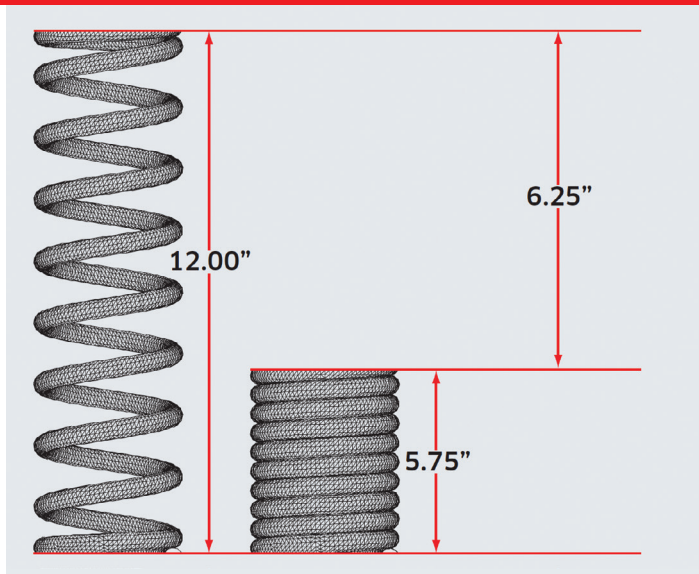

STEP 2: DETERMINE TEST RANGE

Calculate the first test point by taking 20% of 6.25" (which equals 1.25") or 20% of 146mm (which equals 29.20mm) and the second test point by taking 70% of 6.25" (which equals 4.375") or 70% of 146mm (which equals 102.20mm). The actual travel between these two points (3.125") or (73mm) is where we determine the spring rate.

STEP 3: SPRING RATE TEST

Preload the spring 1.25" or 29.20mm and record the force measurement. Continue to compress the spring an additional 3.125" (total compression of 4.375") or 73mm (total compression of 102.20mm) and record the force measurement. Calculate and record the difference in force between the two points (1.25" >< 4.375") or (29.20mm >< 102.20mm). In our example the difference would be approximately 1565lbs or 7300N.

FREE LENGTH 20% PRELOAD 70% PRELOAD

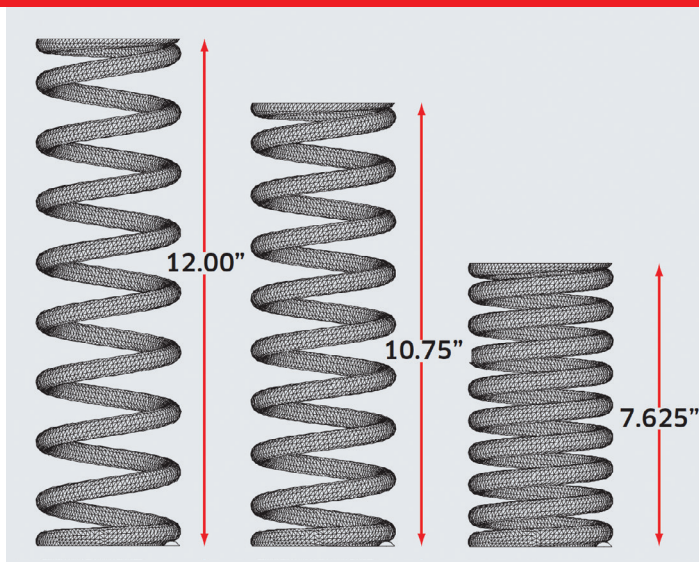

STEP 4: SPRING RATE CALCULATION

With Eibach's precise spring rate tolerance of +/- 2% (500 x 2% = 10 lbs) the spring rate should fall between 490 and 510 lbs/in (1565 / 3.125 = 500lb) or 95N and 105N (7300N / 73mm = 100N/mm).

CONVERSION RATES

IMPERIAL TO METRIC

1 inch = 25.4 MM

1 lb = 4.448 Newton

1 lb = 0.453 Kilogram

METRIC TO IMPERIAL

1 MM = 0.03937 inch

1 Newton = 0.2248 lb

1 Kilogram = 2.20 lbs